

AVTECH ELECTROSYSTEMS LTD.

NANOSECOND WAVEFORM ELECTRONICS  
SINCE 1975

□ P.O. BOX 265  
OGDENSBURG, NY  
U.S.A. 13669-0265  
TEL: (315) 472-5270  
FAX: (613) 226-2802

TEL: 1-800-265-6681  
FAX: 1-800-561-1970

e-mail: [info@avtechpulse.com](mailto:info@avtechpulse.com)  
<http://www.avtechpulse.com/>

☒ BOX 5120, LCD MERIVALE  
OTTAWA, ONTARIO  
CANADA K2C 3H4  
TEL: (613) 226-5772  
FAX: (613) 226-2802

INSTRUCTIONS

MODEL AVM-1-C

0 TO 5 VOLTS, 25 MHz

HIGH SPEED PULSE GENERATOR

WITH 100 ps RISE TIME

SERIAL NUMBER: \_\_\_\_\_

### WARRANTY

Avtech Electrosystems Ltd. warrants products of its manufacture to be free from defects in material and workmanship under conditions of normal use. If, within one year after delivery to the original owner, and after prepaid return by the original owner, this Avtech product is found to be defective, Avtech shall at its option repair or replace said defective item. This warranty does not apply to units which have been disassembled, modified or subjected to conditions exceeding the applicable specifications or ratings. This warranty is the extent of the obligation assumed by Avtech with respect to this product and no other warranty or guarantee is either expressed or implied.

### TECHNICAL SUPPORT

Phone: 613-226-5772 or 1-800-265-6681

Fax: 613-226-2802 or 1-800-561-1970

E-mail: [info@avtechpulse.com](mailto:info@avtechpulse.com)

World Wide Web: <http://www.avtechpulse.com>

## TABLE OF CONTENTS

<b>WARRANTY</b> .....	<b>2</b>
<b>TECHNICAL SUPPORT</b> .....	<b>2</b>
<b>TABLE OF CONTENTS</b> .....	<b>3</b>
<b>INTRODUCTION</b> .....	<b>5</b>
<b>AVAILABLE OPTIONS</b> .....	<b>6</b>
<b>SPECIFICATIONS</b> .....	<b>7</b>
<b>EUROPEAN REGULATORY NOTES</b> .....	<b>8</b>
EC DECLARATION OF CONFORMITY.....	<b>8</b>
DIRECTIVE 2002/95/EC (RoHS).....	<b>8</b>
<b>INSTALLATION</b> .....	<b>9</b>
VISUAL CHECK.....	<b>9</b>
POWER RATINGS.....	<b>9</b>
CONNECTION TO THE POWER SUPPLY.....	<b>9</b>
ENVIRONMENTAL CONDITIONS.....	<b>10</b>
<b>FUSES</b> .....	<b>11</b>
AC FUSE REPLACEMENT.....	<b>11</b>
DC FUSE REPLACEMENT.....	<b>12</b>
FUSE RATINGS.....	<b>12</b>
<b>FRONT PANEL CONTROLS</b> .....	<b>13</b>
<b>REAR PANEL CONTROLS</b> .....	<b>16</b>
<b>GENERAL INFORMATION</b> .....	<b>18</b>
BASIC TEST ARRANGEMENT.....	<b>18</b>
GENERAL OPERATING NOTES.....	<b>18</b>
AMPLITUDE INTERACTION.....	<b>20</b>
POLARITY INVERSION.....	<b>20</b>
<b>MINIMIZING WAVEFORM DISTORTIONS</b> .....	<b>21</b>
USE 50 OHM TRANSMISSION LINES AND LOADS.....	<b>21</b>
USE LOW-INDUCTANCE LOADS.....	<b>21</b>
<b>PREVENTING DAMAGE</b> .....	<b>21</b>
<b>MECHANICAL INFORMATION</b> .....	<b>22</b>
TOP COVER REMOVAL.....	<b>22</b>
ELECTROMAGNETIC INTERFERENCE.....	<b>22</b>

- MAINTENANCE..... 22**
  - REGULAR MAINTENANCE.....22
  - CLEANING.....22
- WIRING DIAGRAMS..... 23**
  - WIRING OF AC POWER.....23
  - PCB 158G - LOW VOLTAGE POWER SUPPLY, 1/3.....24
  - PCB 158G - LOW VOLTAGE POWER SUPPLY, 2/3.....25
  - PCB 158G - LOW VOLTAGE POWER SUPPLY, 3/3.....26
  - MAIN WIRING.....27
- PERFORMANCE CHECK SHEET..... 28**

Manual Reference: T:\instructword\avm\AVM-1-C, edition 8.sxw.  
Last modified January 26, 2005.  
Copyright © 2005 Avtech Electrosystems Ltd, All Rights Reserved.

## INTRODUCTION

The AVM-1-C is a high performance instrument capable of generating up to 5V into 50 $\Omega$  loads at repetition rates up to 25 MHz. The output pulse width is variable from 0.2 to 6 ns. The rise time is less than 100 ps, and the fall time is less than 135 ps.

Instruments with the "-P" model suffix can generate 0 to +5V, whereas instruments with the "-N" model suffix can generate 0 to -5V.

Instruments with the "-P-PN" suffix generate 0 to +5V at the main output, and are supplied with an inverting transformer that can be installed on the output to generate a negative signal.

Instruments with the "-N-PN" suffix generate 0 to -5V at the main output, and are supplied with an inverting transformer that can be installed on the output to generate a positive signal.

The output is designed to drive 50 $\Omega$  loads. (A 50 $\Omega$  load is required for proper operation.) The output is AC-coupled.

This instrument is intended for use in research and development laboratories.

### AVAILABLE OPTIONS

The AVM-1-C is available with several options:

-D Option: this option adds a 0-5 ns adjustable delay feature, which operates in both the internal and external trigger modes.

-ECL Option: the input trigger levels are ECL, rather than TTL.

-EA Option: the output amplitude can be controlled by an externally generated 0 to +10V analog control voltage.

-ED Option: the 0-5 ns delay can be controlled by an externally generated 0 to +10V analog control voltage. Units with the -ED option incorporate the -D option as well.

-EA Option: the output offset can be controlled by an externally generated 0 to +10V analog control voltage.

-EW Option: the output pulse width can be controlled by an externally generated 0 to +10V analog control voltage.

-M Option: a monitor output is provided.

-OT Option: an internally generated DC offset, controlled by a front-panel dial, can be added to the output.

## SPECIFICATIONS

Model:	AVM-1-C <sup>1</sup>
Amplitude <sup>2,3</sup> :	Variable to 5 Volts (50 Ohm load)
Pulse width (FWHM) <sup>2</sup> :	Variable 0.2 to 6 ns
PRF:	0 to 25 MHz (-C units & modules, externally triggered) 3 kHz to 25 MHz (-C units, internally triggered)
Rise time (20%-80%):	≤ 100 ps
Fall time (80%-20%):	≤ 135 ps (typically 100 ps)
Polarity <sup>4</sup> :	Positive or negative or both (specify)
Propagation delay:	≤ 30 ns (Ext trig in to pulse out)
Variable propagation delay option <sup>2,5</sup> :	0 to 5 ns
Jitter:	± 15 ps (Ext trig in to pulse out)
DC offset or bias insertion <sup>2,6</sup> :	Apply required DC offset to back panel solder terminals (± 50 Volts, 250 mA max)
Trigger required:	Ext trig mode: +5 Volts, 10 ns or wider (TTL)
Sync delay:	Sync out to pulse out: Variable 0 to 85 ns
Sync output:	Approximately 20 ns wide and 0.5V in amplitude. Logically complemented (i.e., LOW ≈ +0.5V, HIGH ≈ 0V). Will drive 50 Ohm loads.
Monitor output option <sup>7</sup> :	Provides a 20 dB attenuated coincident replica of main output
Connectors:	Out, Monitor: SMA, Trig, Sync: BNC
Power:	100 - 240 Volts, 50 - 60 Hz
Dimensions:	100 mm x 215 mm x 375 mm (3.9" x 8.5" x 14.8")

1. -C suffix indicates stand-alone lab instrument with internal clock and line powering. No suffix indicates miniature module requiring DC power and external trigger. (See page 112 for additional details of the basic instrument formats).
2. For electronic control (0 to +10V) of amplitude, pulse width, delay or offset suffix model number with -EA or -EW or -ED or -EO. Electronic control units also include the standard front panel one-turn controls.
3. For operation at amplitudes of less than 10% of full-scale, best results will be obtained by setting the amplitude near full-scale and using external attenuators on the output.
4. Indicate desired polarity by suffixing model number with -P or -N (i.e. positive or negative) or -P-PN or -N-PN for dual polarity option where the suffix preceding -PN indicates the polarity at the mainframe output port. (-PN available only for -C units).
5. Indicate delay option by suffixing model number with -D.
6. For internally generated DC offset option (0 to ±5 V, one turn control) add suffix -OT to model number. -OT and -EO options not available on modules.
7. For monitor option add suffix -M.

## EUROPEAN REGULATORY NOTES

### EC DECLARATION OF CONFORMITY

We

Avtech Electrosystems Ltd.  
P.O. Box 5120, LCD Merivale  
Ottawa, Ontario  
Canada K2C 3H4

declare that this pulse generator meets the intent of Directive 89/336/EEC for Electromagnetic Compatibility. Compliance pertains to the following specifications as listed in the official Journal of the European Communities:

EN 50081-1 Emission

EN 50082-1 Immunity

and that this pulse generator meets the intent of the Low Voltage Directive 72/23/EEC as amended by 93/68/EEC. Compliance pertains to the following specifications as listed in the official Journal of the European Communities:

EN 61010-1:2001 Safety requirements for electrical equipment for measurement, control, and laboratory use



### DIRECTIVE 2002/95/EC (RoHS)

This instrument is exempt from Directive 2002/95/EC of the European Parliament and of the Council of 27 January 2003 on the Restriction of the use of certain Hazardous Substances (RoHS) in electrical and electronic equipment. Specifically, Avtech instruments are considered "Monitoring and control instruments" (Category 9) as defined in Annex 1A of Directive 2002/96/EC. The Directive 2002/95/EC only applies to Directive 2002/96/EC categories 1-7 and 10, as stated in the "Article 2 - Scope" section of Directive 2002/95/EC.



## INSTALLATION

### VISUAL CHECK

After unpacking the instrument mainframe and the transformer module, examine to ensure that they have not been damaged in shipment. Visually inspect all connectors, knobs, and handles. Confirm that a power cord and an instrumentation manual (this manual), are with the instrument. If the instrument has been damaged, file a claim immediately with the company that transported the instrument.

### POWER RATINGS

This instrument is intended to operate from 100 - 240 V, 50 - 60 Hz.

The maximum power consumption is 57 Watts. Please see the “FUSES” section for information about the appropriate AC and DC fuses.

This instrument is an “Installation Category II” instrument, intended for operation from a normal single-phase supply.

### CONNECTION TO THE POWER SUPPLY

An IEC-320 three-pronged recessed male socket is provided on the back panel for AC power connection to the instrument. One end of the detachable power cord that is supplied with the instrument plugs into this socket. The other end of the detachable power cord plugs into the local mains supply. Use only the cable supplied with the instrument. The mains supply must be earthed, and the cord used to connect the instrument to the mains supply must provide an earth connection. (The supplied cord does this.) The table below describes the power cord that is supplied with this instrument, depending on the destination region:

Destination Region	Description	Volex ( <a href="http://www.volex.com">http://www.volex.com</a> ) Part Number	Newark ( <a href="http://www.newark.com">http://www.newark.com</a> ) Stock Number
Continental Europe	European CEE 7/7 “Schuko” 230V, 50Hz	17850-C3-326	44F1841
United Kingdom	BS 1363, 230V, 50Hz	17962-C3-10	84F1025
Switzerland	SEV 1011, 230V, 50Hz	2102H-C3-10	93F2452
Israel	SI 32, 220V, 50Hz	2115H-C3-10	04F1115
North America, and all other areas	NEMA 5-15, 120V, 60 Hz	17250-B1-10	36F1255

## ENVIRONMENTAL CONDITIONS

This instrument is intended for use under the following conditions:

- a) indoor use;
- b) altitude up to 2 000 m;
- c) temperature 5 °C to 40 °C;
- d) maximum relative humidity 80 % for temperatures up to 31 °C decreasing linearly to 50 % relative humidity at 40 °C;
- e) Mains supply voltage fluctuations up to  $\pm 10$  % of the nominal voltage;
- f) no pollution or only dry, non-conductive pollution.

## FUSES

This instrument contains four fuses. All are accessible from the rear-panel. Two protect the AC prime power input, and two protect the internal DC power supplies. The locations of the fuses on the rear panel are shown in the figure below:

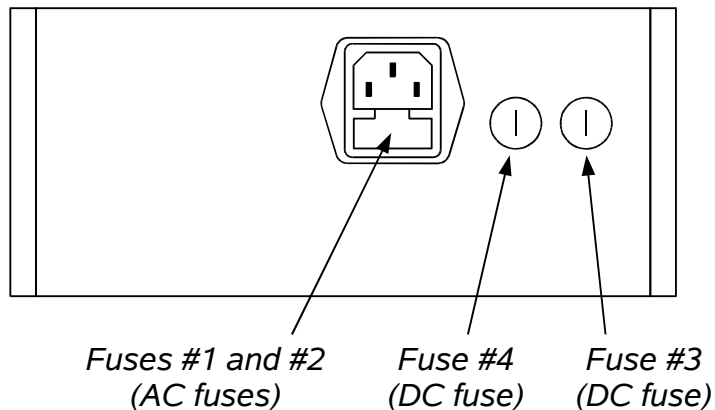

### AC FUSE REPLACEMENT

To physically access the AC fuses, the power cord must be detached from the rear panel of the instrument. The fuse drawer may then be extracted using a small flat-head screwdriver, as shown below:

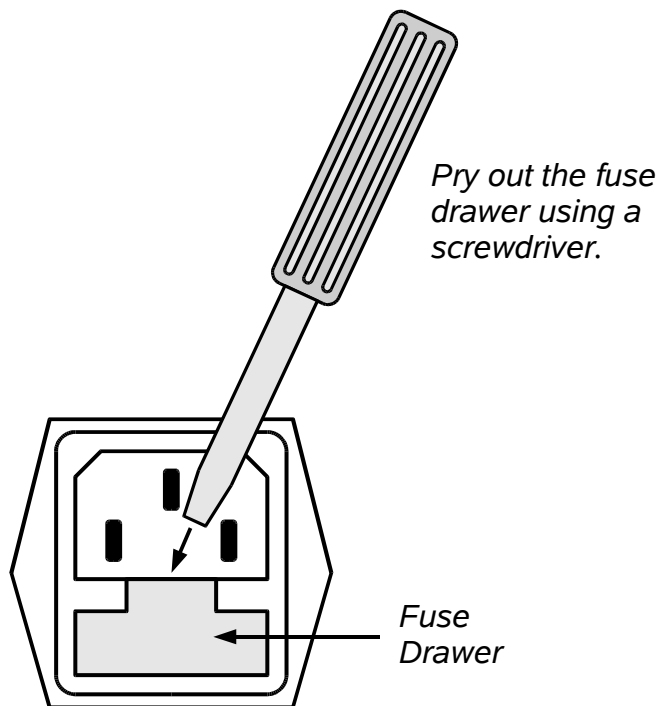

## DC FUSE REPLACEMENT

The DC fuses may be replaced by inserting the tip of a flat-head screwdriver into the fuse holder slot, and rotating the slot counter-clockwise. The fuse and its carrier will then pop out.

## FUSE RATINGS

The following table lists the required fuses:

Fuses	Nominal Mains Voltage	Rating	Case Size	Manufacturer's Part Number (Wickmann)	Distributor's Part Number (Digi-Key)
#1, #2 (AC)	100-240V	0.5A, 250V, Time-Delay	5×20 mm	1950500000	WK5041-ND
#3 (DC)	N/A	1.0A, 250V, Time-Delay	5×20 mm	1951100000	WK5048-ND
#4 (DC)	N/A	0.8A, 250V, Time-Delay	5×20 mm	1950800000	WK5046-ND

The fuse manufacturer is Wickmann (<http://www.wickmann.com/>).

Replacement fuses may be easily obtained from Digi-Key (<http://www.digikey.com/>) and other distributors.

## FRONT PANEL CONTROLS

The layout of the front panel depends slightly on the options ordered:

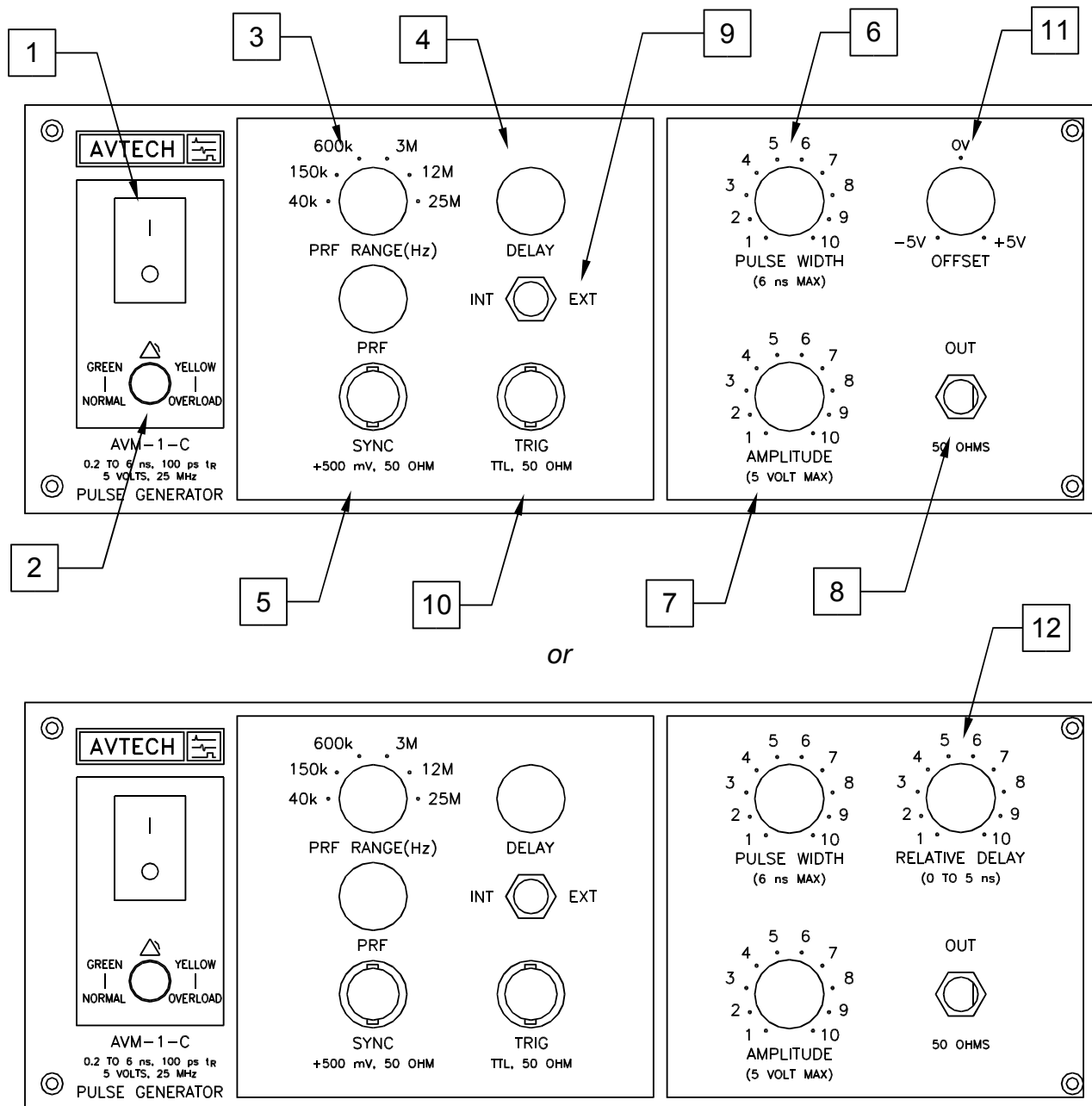

- 1. POWER Switch.** This is the main power switch. When turning the instrument on, there may be a delay of several seconds before the instrument appears to respond.
- 2. OVERLOAD Indicator.** When the instrument is powered, this indicator is normally green, indicating normal operation. If this indicator is yellow, an internal automatic

overload protection circuit has been tripped. If the unit is overloaded (by operating at an exceedingly high duty cycle or by operating into a very low impedance), the protective circuit will disable the output of the instrument and turn the indicator light yellow. The light will stay yellow (i.e. output disabled) for about 5 seconds after which the instrument will attempt to re-enable the output (i.e. light green) for about 1 second. If the overload condition persists, the output will be disabled again (i.e. light yellow) for another 5 seconds. If the overload condition has been removed, the instrument will resume normal operation.

This overload indicator may flash yellow briefly at start-up. This is not a cause for concern.

3. PRF Range Switch and Vernier. This switch sets the pulse repetition frequency (PRF) range of the internal oscillator. The marked value of each position is the upper limit of the range, approximately. The vernier dial directly below the switch varies the PRF within the set range.
4. DELAY Control. Controls the relative delay between the reference output pulse provided at the SYNC output (5) and the main output (8). This delay is variable over the range of 0 to at least 100 ns. This feature is only active when internally triggered.
5. SYNC Output. This output precedes the main output (8) and is used to trigger the sampling scope time base. The output is approximately 20 ns wide, 0.5V in amplitude, and is logically complemented (i.e., LOW  $\approx$  +0.5V, HIGH  $\approx$  0V). It will drive 50 Ohm loads.
6. Pulse Width Control. This dial controls the pulse width. If the -EW option is present, the rear-panel PW INT/EXT switch must be in the INT position for this control to function.
7. Amplitude Control. This dial controls the pulse amplitude. If the -EA option is present, the rear-panel AMP INT/EXT switch must be in the INT position for this control to function.
8. OUT Connector. This is the main output. (This output *requires* a 50 $\Omega$  load to function properly).
9. EXT-INT Control. With this toggle switch in the INT position, the PRF of the unit is controlled via an internal clock, which in turn is controlled by the PRF controls. With the toggle switch in the EXT position, the AVM unit requires a 15 ns (or wider) TTL level pulse applied at the TRIG input in order to trigger the output stages. In addition, in this mode, the scope time base must be triggered by the external trigger source.
10. TRIG Input. The external trigger signal is applied at this input when the EXT-INT toggle switch is in the EXT position.

11. OFFSET Control. (Optional feature. Present on units with the -OT option only.) This dial controls the DC offset added to the output. This offset is variable from -5V to +5V. The rear-panel "Offset On/Off" switch must be set to ON to enable this feature. If the -EO option is present, the rear-panel OS INT/EXT switch must be in the INT position for this control to function.
12. RELATIVE DELAY Control. (Optional feature. Present on units with the -D option only.) The output pulse position or propagation delay can be varied over a 0 to 5 ns range using this control. This delay functions in both the internal and external trigger modes, unlike the standard delay controls (item 4).

## REAR PANEL CONTROLS

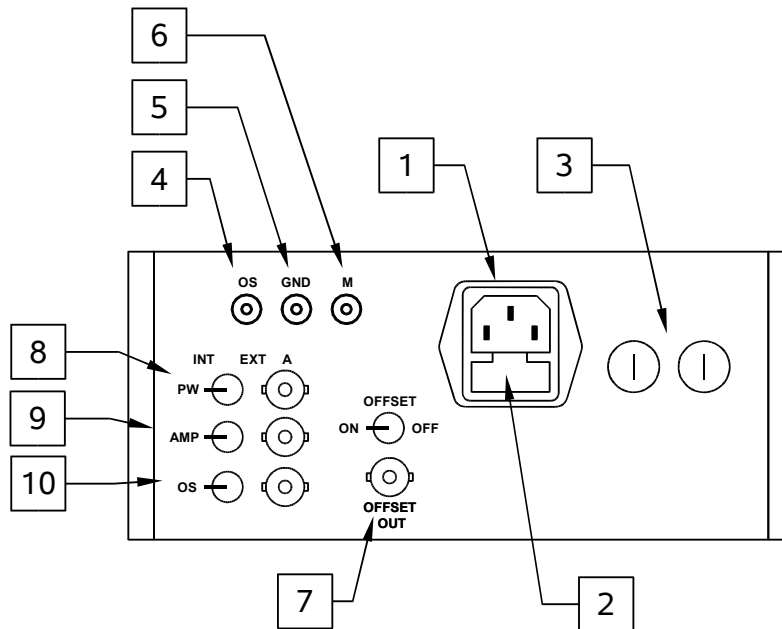

1. AC POWER INPUT. An IEC-320 C14 three-pronged recessed male socket is provided on the back panel for AC power connection to the instrument. One end of the detachable power cord that is supplied with the instrument plugs into this socket.
2. AC FUSE DRAWER. The two fuses that protect the AC input are located in this drawer. Please see the “FUSES” section of this manual for more information.
3. DC FUSES. These two fuses protect the internal DC power supplies. Please see the “FUSES” sections of this manual for more information.
4. OS INPUT CONNECTOR. (For units without -OT or -EO options). A DC offset in the range of  $\pm 50\text{V}$  (250 mA max) may be applied to this solder terminal. The DC offset will appear on the output. When this feature is not used, the OS input should be connected to ground (using the adjacent GND connector). This is especially important when driving loads containing a diode.
5. GND CONNECTOR. This solder terminal is connected to ground. It may be used to ground the OS input connector.
6. M OUTPUT CONNECTOR. (Present on units with -M option only.) This SMA connector output provides a 20 dB attenuated coincident replica of main output, for monitoring purposes.
7. OFFSET ON/OFF SWITCH & OUTPUT (Optional, -EO and -OT units only). This switch enables the offset feature when it is set to “ON”. When it is set to “OFF”, no offset is added to the output. The internally generated offset is available at the



“OFFSET OUT” BNC connector, for monitoring purposes. To add an offset to inverted pulses on AVM units with the dual polarity option (-PN), connect this terminal to the DC terminal of the AVX-2-T inverting transformer (see the “POLARITY INVERSION” sections in this manual for further details).

8. PW INT/EXT SWITCH AND CONNECTOR (Optional, -EW units only). To control the pulse width of the output with an external DC voltage, set the two-position switch to the EXT position and apply 0 to +10V to the BNC Connector ( $R_{IN} \geq 10 \text{ k}\Omega$ ). When this switch is in the “INT” position, the pulse width is controlled by the front-panel controls.
9. AMP INT/EXT SWITCH AND CONNECTOR (Optional, -EA units only). To control the amplitude of the output with an external DC voltage, set the two-position switch to the EXT position and apply 0 to +10V to the BNC Connector ( $R_{IN} \geq 10 \text{ k}\Omega$ ). When this switch is in the “INT” position, the amplitude is controlled by the front-panel controls.
10. OS INT/EXT SWITCH AND CONNECTOR (Optional, -EO units only). To control the offset of the output with an external DC voltage, set the two-position switch to the EXT position and apply 0 to +10V to the BNC Connector ( $R_{IN} \geq 10 \text{ k}\Omega$ ). When this switch is in the “INT” position, the offset is controlled by the front-panel controls.

## GENERAL INFORMATION

### BASIC TEST ARRANGEMENT

The AVM-1-C should be tested with a sampling oscilloscope with a bandwidth of at least 10 GHz to properly observe the high-speed waveform. A typical test arrangement is shown below:

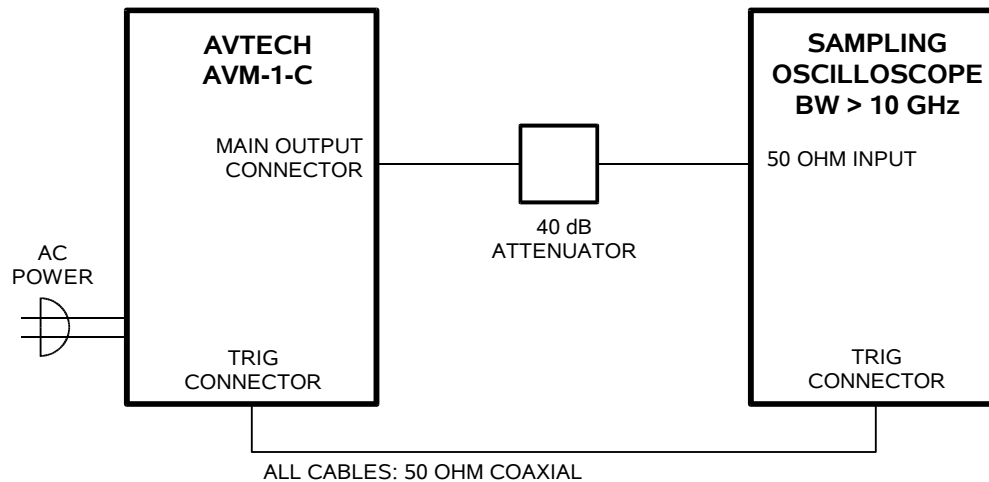

The attenuator is required to prevent damage to the sampling oscilloscope.

### GENERAL OPERATING NOTES

- 1) The bandwidth capability of components and instruments used to display the pulse generator output signal (attenuators, cables, connectors, etc.) should exceed 10 GHz.
- 2) The use of a 40 dB attenuator at the sampling scope vertical input channel will ensure a peak input signal to the sampling scope of less than 1 Volt.
- 3) The sync output channel provides a 20 ns wide, 0.5V, logically complemented (i.e., LOW  $\approx$  +0.5V, HIGH  $\approx$  0V) pulse. It will drive 50 Ohm loads..
- 4) To obtain a stable output display the PRF controls on the front panel should be set mid-range while the PRF range switch may be in either range. The front panel INT/EXT toggle switch should be in the INT position. The front panel DELAY control and the scope triggering controls are then adjusted to obtain a stable output. It is recommended that the DELAY control first be set maximum counter-clockwise and then turned clockwise until a stable display is obtained. The scope may then be used to set the desired PRF by rotating the PRF controls and by means of the PRF range switch. The stability of the display on some sampling scopes is very sensitive to the

trigger delay setting, particularly at high PRF (e.g. 10 to 25 MHz). If necessary, consult your sample scope instructions manual for the proper triggering method.

- 5) The output pulse width is controlled by means of the front panel one-turn PW control. The control should initially be set maximum clockwise and the pulse width adjusted using an oscilloscope. Rotation of the PW pot causes the position of the falling edge of the pulse to change.
- 6) To voltage control the output pulse width, set the rear panel switch in the EXT position and apply 0 to +10V to connector A ( $R_{IN} > 10K$ ). (EW option).
- 7) The output pulse amplitude is controlled by means of the front panel one-turn AMP control. The pulse width may change by several nanoseconds as the output amplitude is reduced from maximum to minimum. Therefore it is convenient to first set the desired amplitude and then set the desired pulse width.
- 8) To voltage control the output amplitude, set the rear panel switch in the EXT position and apply 0 to +10V to connector B ( $R_{IN} > 10K$ ). (EA option).
- 9) To DC offset the output pulse connect a DC power supply set to required DC offset value to the back panel terminals marked OS. The maximum attainable DC offset voltage is +50 Volts (for units without the OT or EO option only).
- 10) For units with the OT or EO options, the output DC offset is variable from +5 to -5 volts by means of the front panel one turn OFFSET control. The offset control may be turned off by means of the rear panel ON-OFF OFFSET switch.
- 11) For units with the EO option, the output offset may be voltage controlled by setting the rear panel switch in the EXT position and applying 0 to +10 volts to connector A ( $R_{IN} > 10K$ ).
- 12) The AVM output pulse position or propagation delay can be varied for up to 5 ns by means of the REALTIVE DELAY control. Rotating this dial clockwise increases the delay. (-D option).
- 13) An external clock may be used to control the output PRF of the AVM unit by setting the front panel TRIG toggle switch in the EXT position and applying a 15 ns (or wider) TTL level pulse to the TRIG BNC connector input. The AVM unit triggers on the rising edge of the input trigger pulse. For operation in this mode, the scope time base must also be triggered by the external clock rather than from the SYNC output.
- 14) **WARNING:** Model AVM-C may fail if triggered at a PRF greater than 25 MHz.

## AMPLITUDE INTERACTION

Some properties of the output pulse may change as a function of the amplitude setting. For some demanding applications, it may be desirable to use a combination of external attenuators and the amplitude pot to achieve the desired output amplitude.

## POLARITY INVERSION

Instruments with the "-P-PN" suffix generate 0 to +5V at the main output, and are supplied with an AVX-2 inverting transformer that can be installed on the mainframe output. A negative pulse is then obtained at the out port of the AVX-2 module.

Instruments with the "-N-PN" suffix generate 0 to -5V at the main output, and are supplied with an AVX-2 inverting transformer that can be installed on the mainframe output. A positive pulse is then obtained at the out port of the AVX-2 module.

When using the transformer with dual-polarity models, the external offset must be added to the DC terminal of the inverting transformer. Do not apply the offset to the rear-panel offset terminal on the mainframe. For units with the OT or EO options, connect a lead from the rear panel OS OUT connector to the DC terminal of the AVX-2-T unit. The DC offset at the output of the AVX-2-T unit is then controlled by the front-panel offset control.

## MINIMIZING WAVEFORM DISTORTIONS

### USE 50 OHM TRANSMISSION LINES AND LOADS

Connect the load to the pulse generator with 50Ω transmission lines (e.g. RG-58 or RG-174 cable).

This instrument requires a 50Ω load for proper operation. It will not properly drive a high-impedance load. The output stage will be damaged if it is operated into an open circuit (or any other high impedance). Failures due to improper output loading are not covered by the warranty.

### USE LOW-INDUCTANCE LOADS

Lenz's Law predicts that for an inductive voltage spike will be generated when the current through an inductance changes. Specifically,  $V_{\text{SPIKE}} = L \times dI_{\text{LOAD}}/dt$ , where L is the inductance,  $I_{\text{LOAD}}$  is the load current change, and t is time. For this reason, it is important to keep any parasitic in the load low. This means keeping wiring short, and using low inductance components. In particular, wire-wound resistors should be avoided.

## PREVENTING DAMAGE

The AVM-1-C may fail if triggered at a PRF greater than 25 MHz.

This unit is designed to operate into a load impedance of 50 Ohms and the output stage will be damaged if it is operated into an open circuit (or any other high impedance). Failures due to improper output loading are not covered by the warranty.

The lifetime of the switching elements in the pulse generator module is proportional to the running time of the instrument. For this reason the prime power to the instrument should be turned off when the instrument is not in use.

## MECHANICAL INFORMATION

### TOP COVER REMOVAL

If necessary, the interior of the instrument may be accessed by removing the four Phillips screws on the top panel. With the four screws removed, the top cover may be slid back (and off).

Always disconnect the power cord before opening the instrument.

There are no user-adjustable internal circuits. For repairs other than fuse replacement, please contact Avtech (info@avtechpulse.com) to arrange for the instrument to be returned to the factory for repair.

 Caution: High voltages are present inside the instrument during normal operation. Do not operate the instrument with the cover removed.

### ELECTROMAGNETIC INTERFERENCE

To prevent electromagnetic interference with other equipment, all used outputs should be connected to shielded 50Ω loads using shielded 50Ω coaxial cables. Unused outputs should be terminated with shielded 50Ω coaxial terminators or with shielded coaxial dust caps, to prevent unintentional electromagnetic radiation. All cords and cables should be less than 3m in length.

## MAINTENANCE

### REGULAR MAINTENANCE

This instrument does not require any regular maintenance.

On occasion, one or more of the four rear-panel fuses may require replacement. All fuses can be accessed from the rear panel. See the “FUSES” section for details.

### CLEANING

If desired, the interior of the instrument may be cleaned using compressed air to dislodge any accumulated dust. (See the “TOP COVER REMOVAL” section for instructions on accessing the interior.) No other cleaning is recommended.

# WIRING DIAGRAMS

## WIRING OF AC POWER

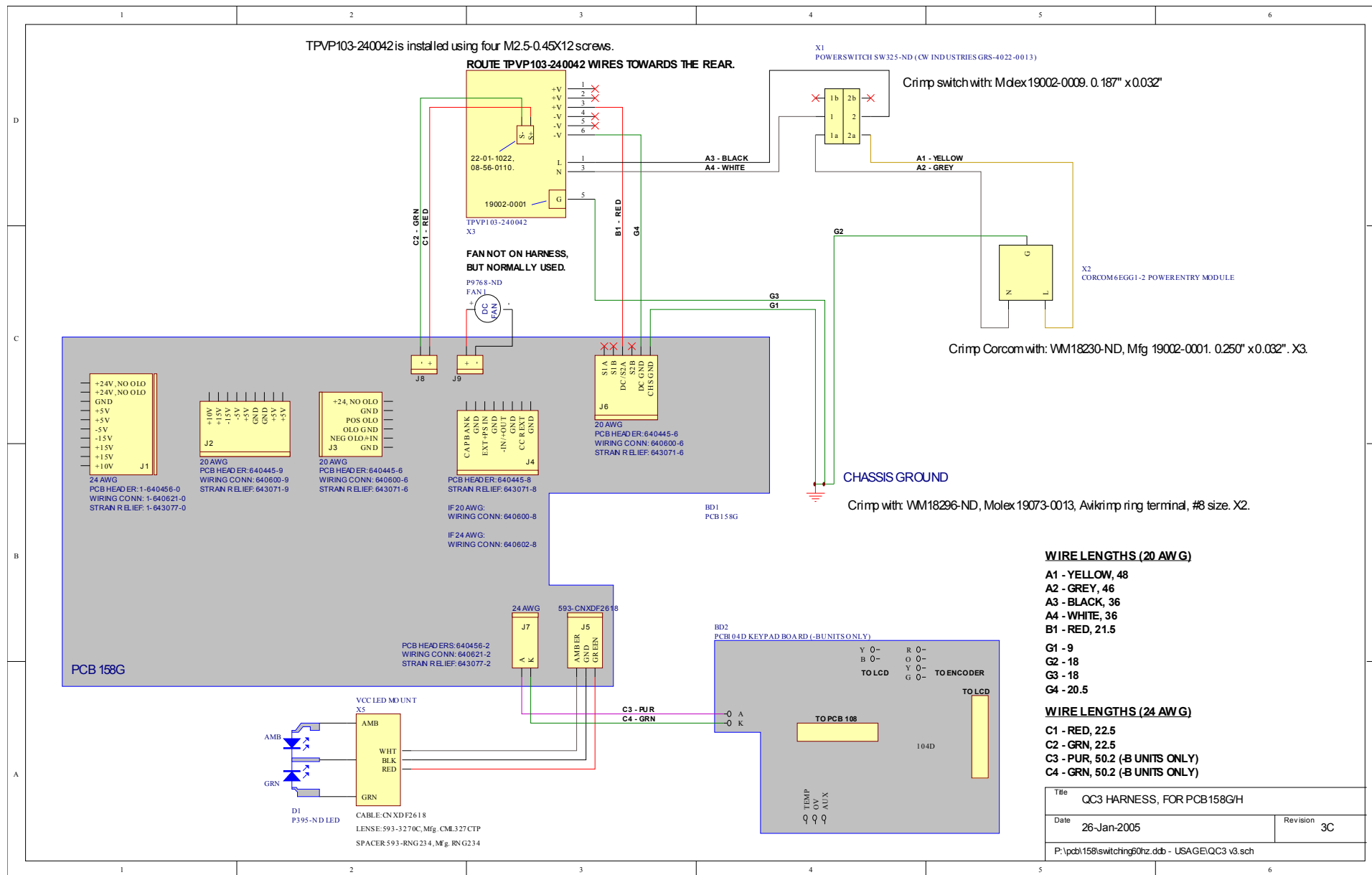

# PCB 158G - LOW VOLTAGE POWER SUPPLY, 1/3

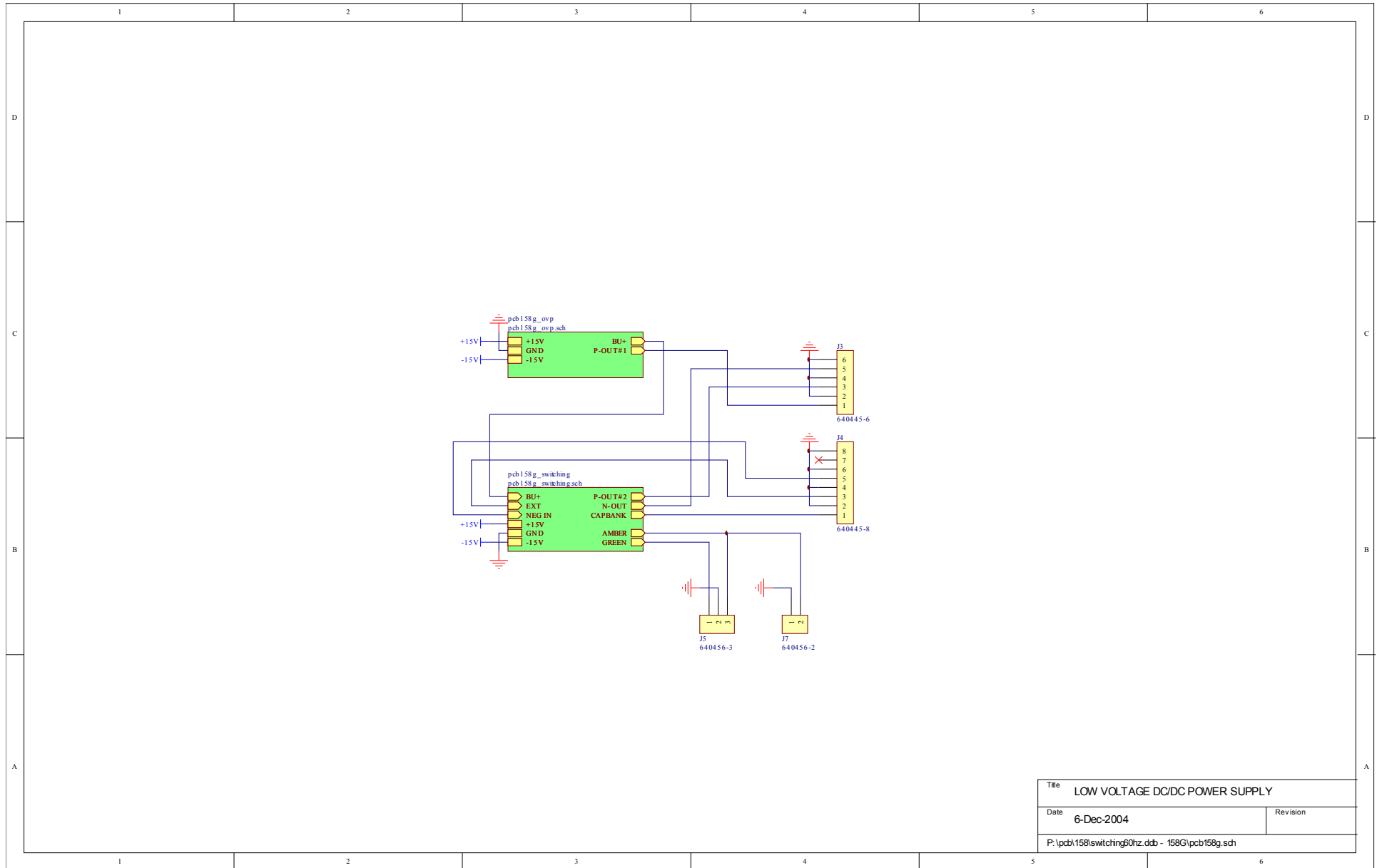

Title		LOW VOLTAGE DC/DC POWER SUPPLY
Date	6-Dec-2004	Revision
P:\pcb\158\switching60hz.ddb - 158G\pcb158g.sch		



# PCB 158G - LOW VOLTAGE POWER SUPPLY, 2/3

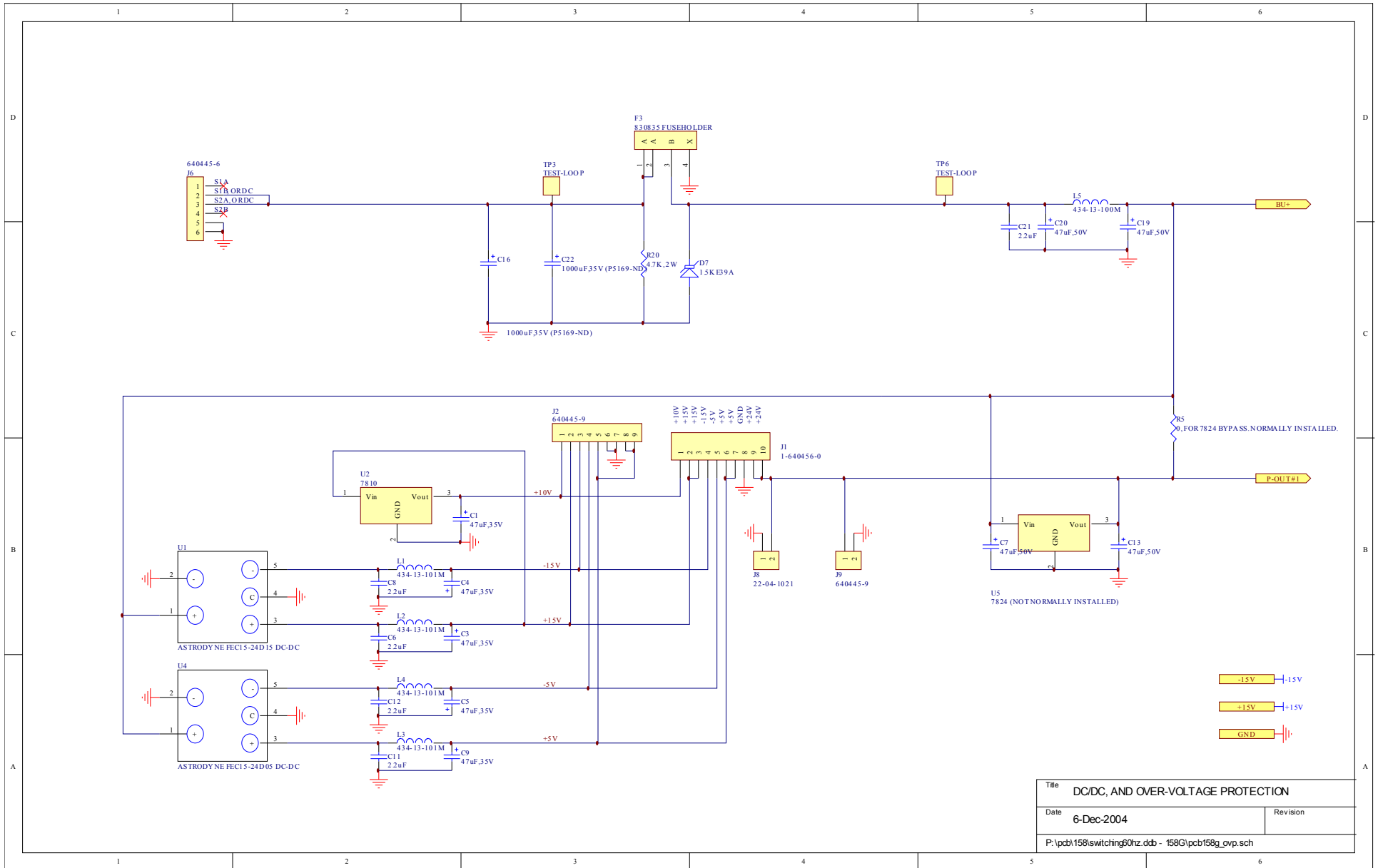

# PCB 158G - LOW VOLTAGE POWER SUPPLY, 3/3

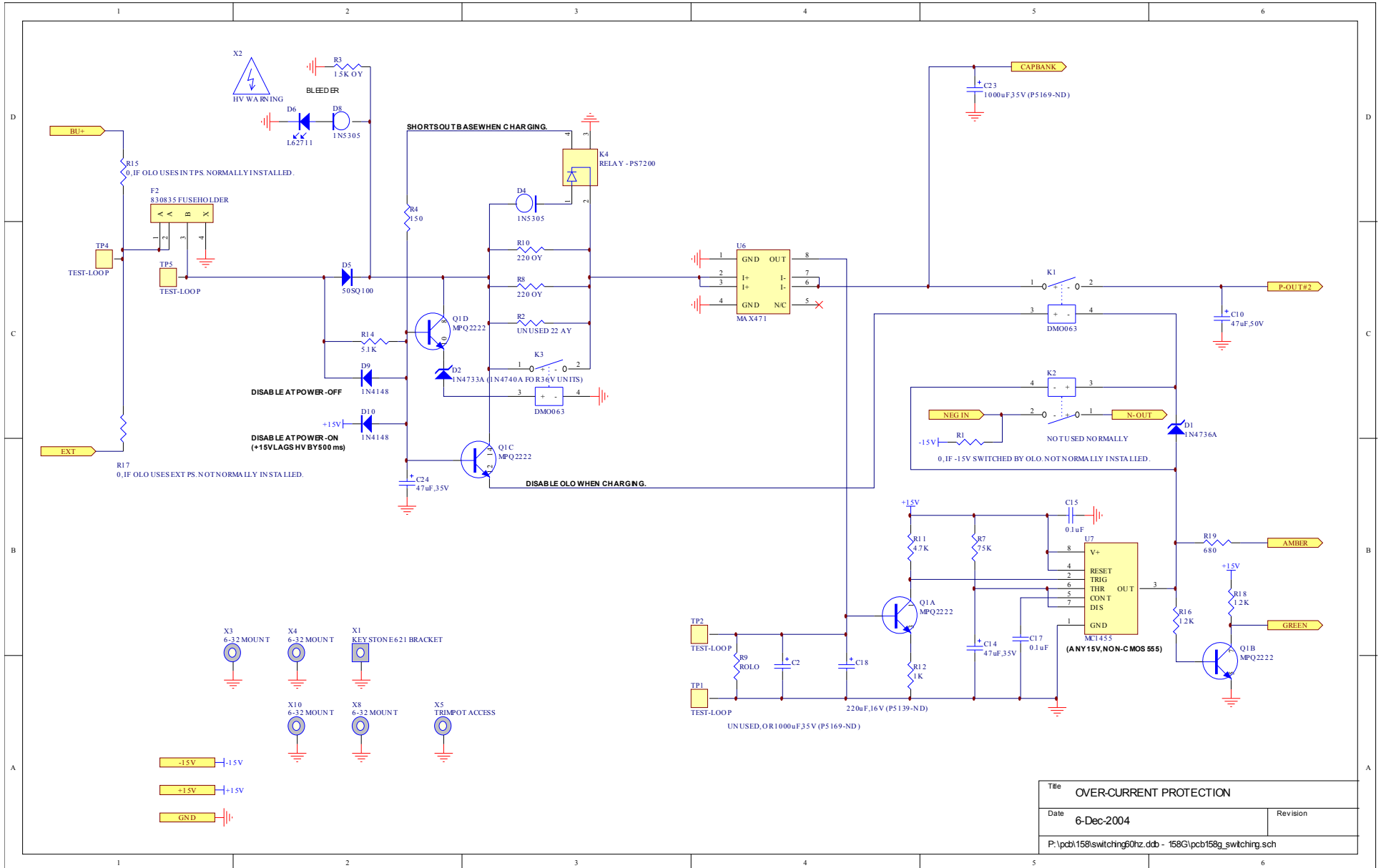

# MAIN WIRING

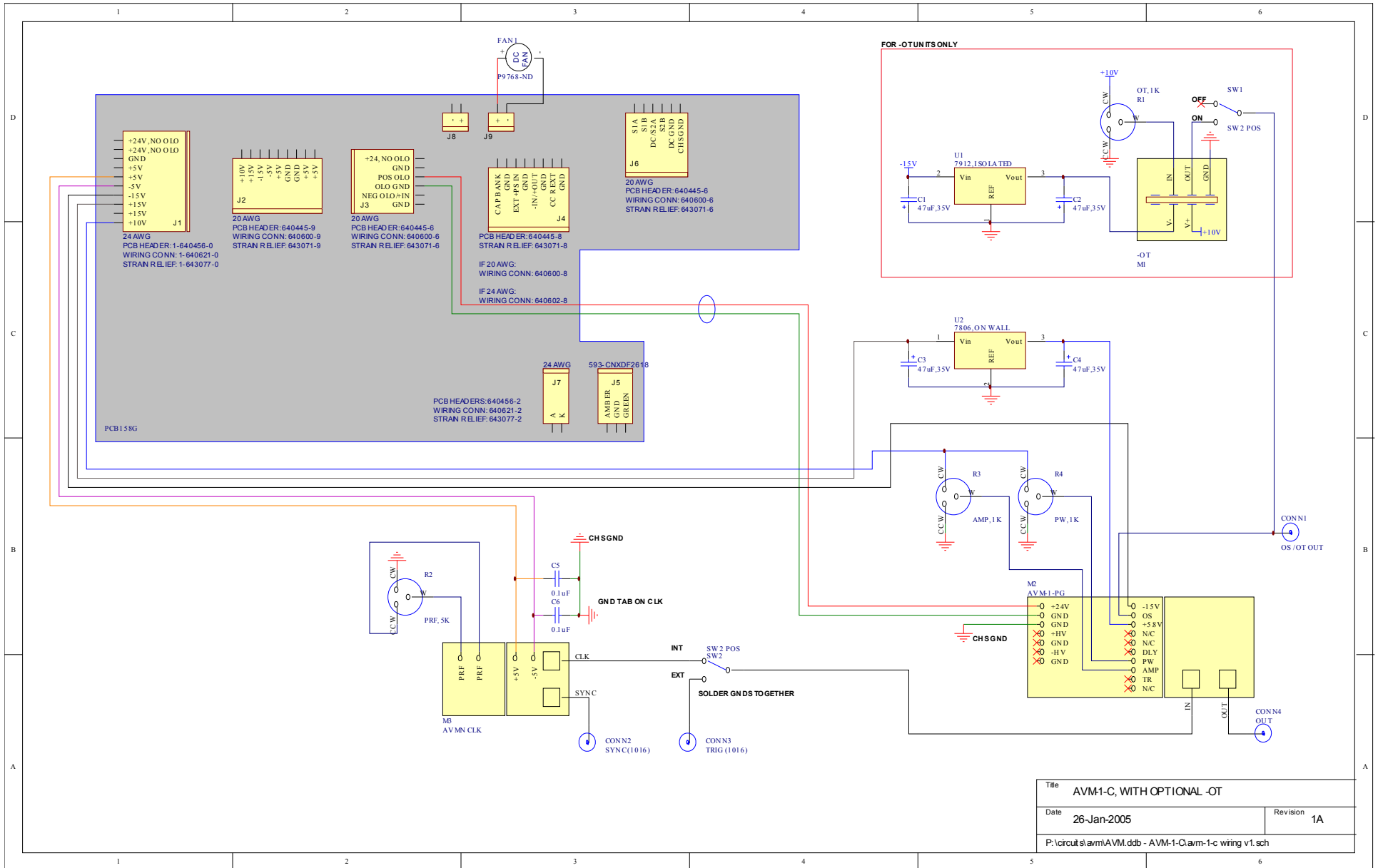

PERFORMANCE CHECK SHEET